

01

Cross Roller Bearing

- Introduction & Model Selection _____ P.04
- Model Characteristics & Features _____ P.05-06
- Formulas _____ P.07-11
- Installation Procedure & Precautions _____ P.12-13
- Accuracy Standards _____ P.14
- Rotational Accuracy _____ P.15-16
- Dimensional Tolerance _____ P.17
- SRAUF Tolerance & Accuracy _____ P.18
- Radial Clearance _____ P.19
- Model Number Composition _____ P.20-30



01

Cross Roller Bearing

Cross Roller Bearing

Cross roller bearings consist of inner rings, outer rings, spacer retainers and cylindrical rollers cross arranged on the V-shaped 90° groove between the inner and outer rings. This structure can withstand radial, axial and moment loads in all directions because the rollers' line contact with raceway surfaces achieve a large load-bearing area despite the minimum dimensions. Therefore these bearings are widely used on the rotating parts of industrial robots, machine tools, precision rotary tables, measuring instruments and IC manufacturing machines.

Product Features

- High rigidity
- Large load capacity
- High rotation accuracy
- Compactness
- Easy to install and handle

Cross Roller Bearing selection

The procedures for the selection and usage of cross roller bearings are based on the following figure

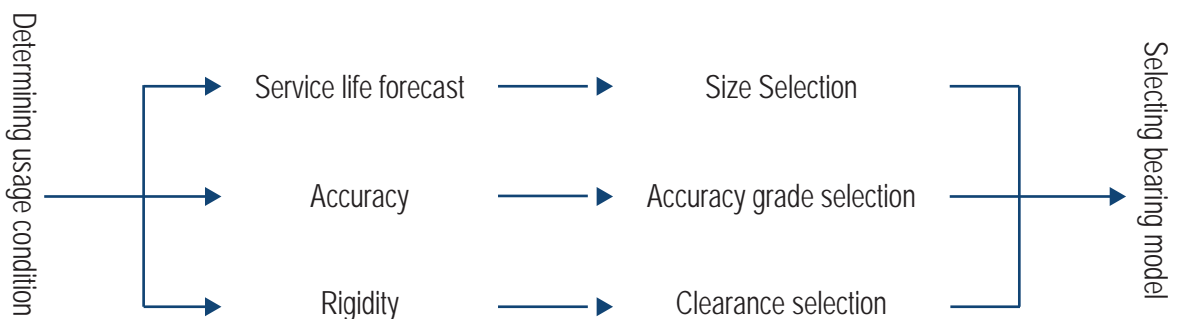

Models & Features



SRU Model (One-Piece Inner & Outer Ring)

The single structure with mounting holes on inner and outer rings does not require the use of flange discs or housings; therefore reduces mounting errors, achieves stable rotational accuracy and moment torque. Suitable for inner and outer ring rotation

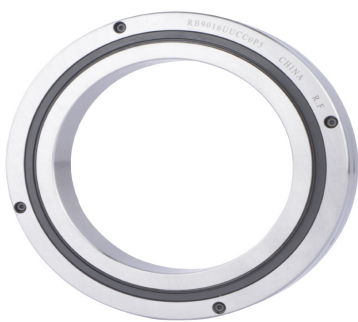

SRB models (Split Outer Ring model for inner ring rotation)

Standard model with two split outer rings bolted together and a one-piece inner ring suitable for precision inner ring rotation.



SRBE Model (One-Piece Inner & Outer Ring)

The one-piece inner & outer ring structure provides high rigidity, high accuracy and smooth rotation; suitable for inner and outer ring rotation

SRAU Model (One-Piece Inner & Outer Ring)

Super slim type cross roller bearing with three options of bearing width: 5mm, 8mm and 13mm. Rigid and compact design is suitable for limited space and lightweight mechanism.

SRAUF (One-Piece Inner & Outer Ring)

Super slim cross roller bearing with mounting holes. Designs for easy installation that significantly reduces equipment weight and size.

SSHF Model (One-Piece Inner & Outer Ring)

Specifically designed for SHF type strain wave gears, this cross roller bearing has mounting holes for easy installation.

SCSG Model (Split outer ring)

Specifically designed for CSG type strain wave gears, this cross roller bearing has mounting holes for easy installation.

Basic Rated Life

The 90% of a group of identical Cross Roller Bearings can operate individually under the same conditions without showing material damage such as flaking caused by rolling fatigue. The basic rated life is represented by the total service hours for rotations at a constant rotational speed.

The service life of the cross roller bearing is calculated using the following formula:

L : basic rated life

C : basic dynamic load rating

P : dynamic-equivalent load

The number of revolutions is expressed in the unit of 10^6 (rev)

$$L = \left(\frac{C}{P} \right)^{\frac{10}{3}}$$

Dynamic Equivalent Radial Load : P

The dynamic-equivalent radial load on cross roller bearings is calculated using the following formula:

P : dynamic-equivalent radial load (kN)

Fr : radial load (kN)

Fa : axial load (kN)

M : moment (kN·mm)

X : dynamic radial coefficient (see table1)

Y : dynamic axial coefficient (see table1)

dw : pitch circle diameter of rollers (mm)

$$P = X \cdot \left(Fr + \frac{2M}{dw} \right) + Y \cdot Fa$$

Dynamic Equivalent Radial Load : P

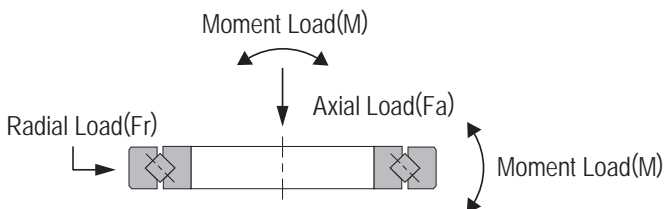

(table 1)

Dynamic radial and axial coefficients

Categories	X	Y
$\frac{Fa}{Fr+2M/dw} \leq 1.5$	1	0.45
$\frac{Fa}{Fr+2M/dw} > 1.5$	0.67	0.67

An example for rated life calculation

Calculate the rated life when bearings are used under the following conditions

$$\text{ID} : d=110 \text{ (mm)} \quad W_1 = 700 \text{ (N)} \quad Fr = 2500 \text{ (N)}$$

$$\text{OD} : D=160 \text{ (mm)} \quad W_2 = 2000 \text{ (N)} \quad L = 700 \text{ (mm)}$$

Example: Model SRB11020

$$\text{Pitch circle diameter} : dw = 135 \text{ (mm)}$$

$$\text{Basic dynamic load rating } C = 34000\text{N}$$

$$\text{Basic static load rating } C_0 = 54000\text{N}$$

$$\text{Radial load} : Fr = 2500 \text{ (N)}$$

$$\text{Axial load} : Fa = W_1 + W_2 = 700 + 2000 = 2700 \text{ (N)}$$

$$\text{Moment load} : M = W_1 \times L = 700 \times 700 = 490000 \text{ (N} \cdot \text{mm)}$$

$$\text{PCD} : dw = (d+D)/2 = (110+160)/2 = 135 \text{ (mm)}$$

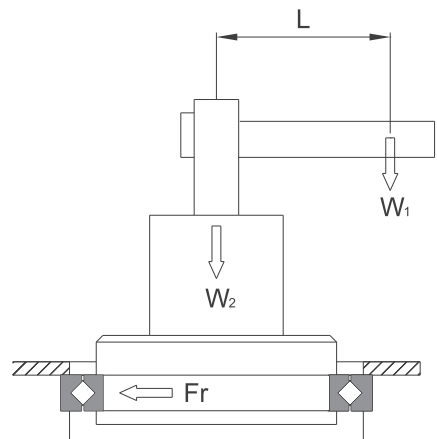

$$\frac{Fa}{Fr+2M/dw} = \frac{2700}{2500+2 \times 490000/135} \cong 0.2766 < 1.5$$

Hence, if radial load coefficient: $x=1$, axial load

coefficient: $y=0.45$, then dynamic-equivalent radial load:

$$P = X \cdot \left(Fr + \frac{2M}{dw} \right) + Y \cdot Fa = 1 \times \left(2500 + \frac{2 \times 490000}{135} \right) + 0.45 \cdot 2700 = 10974 \text{ (N)}$$

$$\text{Basic rated life} : L = \left(\frac{C}{P} \right)^{\frac{10}{3}} = \left(\frac{34000}{10974} \right)^{\frac{10}{3}} = 43.35^6 \text{ (x10 rev)}$$

Static safety coefficient

This coefficient is determined by the basic static rated load (C_0) and static-equivalent radial load (P_0). When a load is statically or dynamically applied, the static safety coefficients shown in the following figure should be considered.

f_s : static safety coefficient

C_0 : basic static rated load (kN)

P_0 : static equivalent radial load (kN)

$$\frac{C_0}{P_0} = f_s$$

(f_s) Static safety coefficient

Load conditions	Lower Limit of f_s
Normal load	1~2
Impact load	2~3

Static equivalent radial load : P_0

The cross roller bearing's static equivalent radial load is calculated using the following formula.

P_0 : Static-equivalent radial load (kN)

F_r : radial load (kN)

F_a : axial load (kN)

M : moment (kN·mm)

X_0 : static radial coefficient ($X_0=1$)

Y_0 : static axial coefficient ($Y_0=0.44$)

d_w : pitch circle diameter of rollers (mm)

$$P_0 = X_0 \cdot \left(F_r + \frac{2M}{d_w} \right) + Y_0 \cdot F_a$$

Fit

Fitting of Models SRU

Fitting required positioning accuracy, h7 and H7 are recommended.

Fitting of Models SRB

Fitting required positioning accuracy are recommended in the following table.

Fitting for Models SRB

Radial Clearance	Service Conditions		Shaft	Housing
C1	Inner ring rotational load	Normal Load	h5	H7
		Large impact and moment	h5	H7
	Outer ring rotational load	Normal Load	g5	Js7
		Large impact and moment	g5	Js7

Methods and design of the housing and flange disc

Due to the thin wall structure of the cross roller bearings, full consideration must be given to the rigidity of the housing and flange discs. With split type bearings, if the housing or flange disc is not rigid enough, the inner ring or outer ring cannot be evenly held, resulting bearing deformation when moment load is applied. Therefore, the contact area of the rollers will become uneven, causing significant decrease in bearing performance.

To prevent this from occurring, it is recommended to design the housing and flange discs by the following methods:

Housing: at least 60% of the sectional height of the cross roller bearing

Housing wall thickness :
$$T = \frac{(D-d)}{2} \times 0.6 \text{ or greater}$$

(D: outer diameter of the outer ring; d: inner diameter of the inner ring)

Tapped hole for bearing removal

Alternatively, tapped holes for removing bearings may be set up on the housing; when it is necessary to remove the bearings from housing, the screws may be locked into the tapped holes to push the bearing out without incurring any damage.

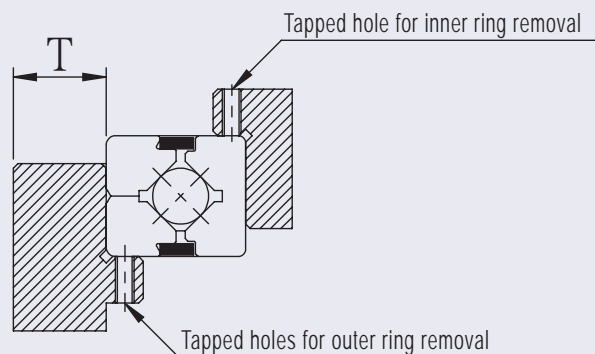

Flange discs and locking screws

The values of the wall thickness (F) or the clearance (S) of the flange discs may be designed per the following formula. As for the quantity of locking screws, it may be configured at equal intervals by using the quantity shown in table (1).

$$F = B \times 0.5 \sim B \times 1.2$$

$$H = B \begin{smallmatrix} 0 \\ -01 \end{smallmatrix}$$

$$S = 0.5 \text{ mm}$$

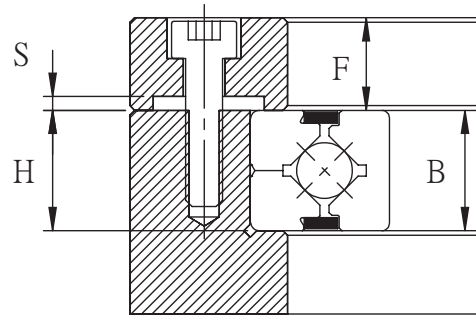

It is recommended to secure the flange discs using materials made of iron. It is advised to firmly lock the screws using torque wrenches. See table (2) for the locking torques of supporting seats or supported flange discs which are made of medium hardness steel.

Table 1. Number of locking screws and size.

Unit : mm

Outer diameter of the outer ring (D)		Number of screws	Screw size (base value)
Above	Below		
-	100	8 or more	M3~M5
100	200	12 or more	M4~M8
200	500	16 or more	M5~M12
500	-	24 or more	M12 or thicker

Table 2. Screw locking torque

Unit : N·m

Screw model	Locking torque	Screw model	Locking torque
M3	2.1	M10	72
M4	3.9	M12	122
M5	9	M16	201
M6	13	M20	392
M8	31	M22	531

Installation steps

Please follow below steps when installing cross roller bearings:

1. Checking each part and component before installing

Clean the housing and other installation components, remove dirt and make sure there are no burrs.

2. Installing the cross roller bearings into housing or onto shaft

The cross roller bearing is easily tilted due to its thin wall structure. To install, level one side, and gradually insert the bearing by evenly and cautiously hammering along the perimeter using a rubber hammer or similar tool until the sound of the ring come in full contact with the mounting surface.

3. Installing the flange disc

- (1) Place the disc into position, shake it along its circumference back and forth several times to match the bolt holes.
- (2) Install screws. When manually turning the screws, make sure that the screw is fully aligned with the screw hole.
- (3) Tighten the screws in the order on the diagonal repeatedly as shown in the following figure, and fasten the disc from loose to tighten in three to four steps. When tightening the split type inner or outer rings, slightly turn the one-piece inner or outer rings to correct the misalignment between the ring and body.

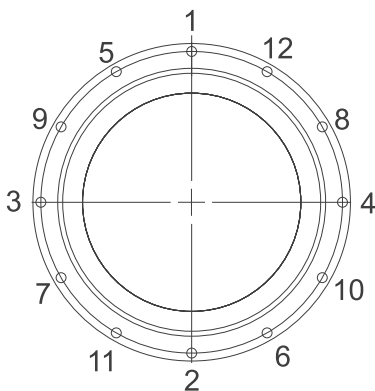

Other precautions

Instructions on lubrication

- (1) Each cross roller bearings are pre-lubricated with high quality lithium soap grease No. 2. However, the bearings need lubricating on a regular basis and users are required to reapply same type of grease at a minimum interval ranging from 6 to 12 months to enable the distribution of grease within the entire internal structure of the bearing; the actual interval depends on the machine or usage.
- (2) Avoid mixing various kinds of lubrication grease.
- (3) When the bearings are used under such special conditions as high vibration, clean rooms, vacuum, low and high temperature, it may be impossible to use general-purpose lubrication grease and please contact us before using special type grease.

Precautions on use

- (1) Foreign objects entering the interior of the bearings may damage the revolution path of the rollers or disable their functions; take caution to prevent foreign objects entering the bearing.
- (2) If bearings are used at an ambient temperature above 80°C, contact us first.
- (3) When foreign objects enter the interior of bearings, apply lube oil again after cleaning the product.
- (4) Do not attempt to remove the screws and nuts on the split type bearings.

Accuracy Standards

SRU、SRB、SRBE inner diameter dimensional accuracy

Unit : μm

Inner ring diameter (d) Nominal dimension (mm)		Tolerance dm					
		0、P5、P4、P2		PS5		PS4、PS2	
Above	Below	Above	Below	Above	Below	Above	Below
18	30	0	-10	0	-6	0	-5
30	50	0	-12	0	-8	0	-6
50	80	0	-15	0	-9	0	-7
80	120	0	-20	0	-10	0	-8
120	150	0	-24	0	-12	0	-9
150	180	0	-24	0	-12	0	-10
180	250	0	-30	0	-14	0	-12
250	315	0	-34	0	-17	-	-

SRU、SRB、SRBE outer diameter dimensional accuracy

Unit : μm

Outer ring diameter (D) Nominal dimension (mm)		Tolerance dm					
		0、P5、P4、P2		PS5		PS4、PS2	
Above	Below	Above	Below	Above	Below	Above	Below
30	50	0	-11	0	-7	0	-6
50	80	0	-13	0	-9	0	-7
80	120	0	-15	0	-10	0	-8
120	150	0	-18	0	-10	0	-9
150	180	0	-24	0	-12	0	-9
180	250	0	-30	0	-15	0	-10
250	315	0	-34	0	-18	0	-12

SRAU ID and OD dimensional accuracy

Unit : μm

Inner ring diameter (d) Nominal dimension (mm)		SRAU Inner Ring		SRAU Outer Ring	
		Above	Below	Above	Below
-	18	0	-8	-	-
18	30	0	-10	0	-9
30	50	0	-12	0	-11
50	80	0	-15	0	-13
80	120	0	-20	0	-15
120	150	0	-25	0	-18
150	180	0	-25	0	-25
180	315	0	-30	0	-30

SRU inner ring rotational accuracy

Unit : μm

Model	Inner ring radial/axial run-out tolerance		
	P5	P4	P2
SRU42	4	3	2.5
SRU66	5	4	2.5
SRU85	5	4	2.5
SRU124	5	4	2.5
SRU148	6	5	2.5
SRU178	6	5	2.5
SRU228	8	6	5

SRU outer ring rotational accuracy

Unit : μm

Model	Outer ring radial/axial run-out tolerance		
	P5	P4	P2
SRU42	8	5	4
SRU66	10	6	5
SRU85	10	6	5
SRU124	12	8	5
SRU148	15	10	7
SRU178	15	10	7
SRU228	18	11	7

SRB、SRBE inner ring rotational accuracy

Unit : μm

Inner ring diameter (d) Nominal dimension (mm)		Inner ring radial run-out tolerance				Inner ring axial run-out tolerance			
Above	Below	0	PS5 P5	PS4 P4	PS2 P2	0	PS5 P5	PS4 P4	PS2 P2
18	30	12	4	3	2.5	12	4	3	2.5
30	50	13	5	4	2.5	13	5	4	2.5
50	80	15	5	4	2.5	15	5	4	2.5
80	120	20	6	5	2.5	20	6	5	2.5
120	150	20	8	6	2.5	20	8	6	2.5
150	180	25	8	6	5	25	8	6	5
180	250	25	10	8	5	25	10	8	5
250	315	35	13	10	-	35	13	10	-

SRBE outer ring rotational accuracy

Unit : μm

Outer ring diameter (D) Nominal dimension (mm)		Outer ring radial run-out tolerance				Outer ring axial run-out tolerance			
Above	Below	0	PS5 P5	PS4 P4	PS2 P2	0	PS5 P5	PS4 P4	PS2 P2
30	50	20	7	5	2.5	20	7	5	2.5
50	80	25	8	5	4	25	8	5	4
80	120	35	10	6	5	35	10	6	5
120	150	40	11	7	5	40	11	7	5
150	180	45	13	8	5	45	13	8	5
180	250	50	15	10	7	50	15	10	7
250	315	60	18	11	7	60	18	11	7

SRAU inner ring rotational accuracy

Unit : μm

Inner ring diameter (d) Nominal dimension (mm)		Inner ring radial run-out tolerance				Inner ring axial run-out tolerance			
Above	Below	0	P6	P5	P4	0	P6	P5	P4
-	18	10	8	5	4	10	8	5	4
18	40	13	10	5	4	13	10	5	4
40	65	13	10	5	4	13	10	5	4
65	80	15	10	5	4	15	10	5	4
80	100	15	13	6	5	15	13	6	5
100	120	20	13	6	5	20	13	6	5
120	140	25	18	8	6	25	18	8	6
140	180	25	18	8	6	25	18	8	6
180	200	30	20	10	8	30	20	10	8

SRAU outer ring rotational accuracy

Unit : μm

Outer ring diameter (d) Nominal dimension (mm)		Outer ring radial run-out tolerance				Outer ring axial run-out tolerance			
Above	Below	0	P6	P5	P4	0	P6	P5	P4
-	65	13	11	-	-	13	11	-	-
65	80	13	11	8	5	13	11	8	5
80	100	15	13	10	6	15	13	10	6
100	120	15	13	10	6	15	13	10	6
120	140	20	15	11	7	20	15	11	7
140	180	25	20	11	7	25	20	11	7
180	200	25	20	15	10	25	20	15	10
200	250	30	25	15	10	30	25	15	10

Inner & Outer ring width tolerances

SRU Inner & Outer ring width tolerances

Unit : μm

Model	Tolerances	
	Above	Below
SRU42	0	-70
SRU66	0	-70
SRU85	0	-70
SRU124	0	-70
SRU148	0	-70
SRU178	0	-80
SRU228	0	-80

SRB Inner & Outer ring width tolerances (for all grades)

Unit : μm

Inner ring diameter (d) Nominal dimension (mm)		Tolerances		Tolerances	
		Inner Ring		Outer Ring	
Above	Below	Above	Below	Above	Below
18	30	0	-70	0	-90
30	50	0	-70	0	-90
50	80	0	-70	0	-90
80	120	0	-70	0	-90
120	150	0	-80	0	-100
150	180	0	-80	0	-100
180	250	0	-80	0	-100
250	315	0	-80	0	-130

SRBE Inner & Outer ring width tolerances

Tolerances	
Maximum	Minimum
0	-75

SRAU Inner & Outer ring width tolerances

Tolerances	
Maximum	Minimum
0	-120

SRAUF Mounting Hole Type Super Slim Cross Roller Bearing

SRAUF ID & OD dimensional accuracy

Unit : μm

Inner ring diameter (d) Nominal dimension (mm)		Inner Ring		Outer Ring	
Above	Below	Above	Below	Above	Below
10	20	0	-8	0	-9
20	30	0	-8	0	-9
30	40	0	-10	0	-13
40	50	0	-10	0	-13

SRAUF inner ring rotational accuracy

Unit : μm

Inner ring diameter (d) Nominal dimension (mm)		Inner ring radial run-out tolerance				Inner ring axial run-out tolerance			
Above	Below	0	P6	P5	P4	0	P6	P5	P4
10	20	13	8	4	3	13	8	4	3
20	30	13	8	5	4	13	8	5	4
30	40	13	10	5	4	13	10	5	4
40	50	15	10	5	4	15	10	5	4

SRAUF Outer ring rotational accuracy

Unit : μm

Outer ring diameter (d) Nominal dimension (mm)		Outer ring radial run-out tolerance				Outer ring axial run-out tolerance			
Above	Below	0	P6	P5	P4	0	P6	P5	P4
40	50	20	10	7	5	20	10	7	5
50	60	20	13	8	5	20	13	8	5
60	70	25	13	8	5	25	13	8	5
70	80	25	13	8	5	25	13	8	5

SRAUF Inner & Outer ring width tolerances SRAUF radial clearance

Unit : μm

Tolerances	
Maximum	Minimum
0	-75

S1 Radial Clearance		C1 Radial Clearance	
Minimum	Maximum	Minimum	Maximum
-8	0	0	15
-8	0	0	15
-8	0	0	15
-8	0	0	15

Radial Clearances

SRU model radial clearance

Unit : μm

Model	S1 Radial Clearance		C1 Radial Clearance	
	Minimum	Maximum	Minimum	Maximum
SRU42	-8	0	0	24
SRU66	-8	0	0	28
SRU85	-8	0	0	38
SRU124	-12	0	0	38
SRU148	-12	0	0	38
SRU178	-12	0	0	48
SRU228	-12	0	0	58

SRB、SRBE model radial clearance

Unit : μm

Roller Pitch Circle Diameter (dw) (mm)		S1 Radial Clearance		C1 Radial Clearance	
Above	Below	Minimum	Maximum	Minimum	Maximum
18	30	-8	0	0	14
30	50	-8	0	0	24
50	80	-8	0	0	28
80	120	-8	0	0	38
120	140	-8	0	0	38
140	160	-10	0	0	38
160	180	-10	0	0	48
180	200	-10	0	0	48
200	225	-10	0	0	58
225	250	-10	0	0	58
250	280	-14	0	0	78
280	315	-14	0	25	98
315	355	-14	0	25	108

SRAU radial clearance

Unit : μm

Roller Pitch Circle Diameter (dw) (mm)		S1 Radial Clearance		C1 Radial Clearance	
Above	Below	Minimum	Maximum	Minimum	Maximum
-	18	-	-	0	15
18	30	-	-	0	15
30	50	-	-	0	15
50	80	-8	0	0	15
80	120	-8	0	0	15
120	140	-8	0	0	15
140	160	-8	0	0	15
160	180	-10	0	0	20
180	200	-10	0	0	20
200	225	-10	0	0	20

SRU (One piece inner & outer ring)

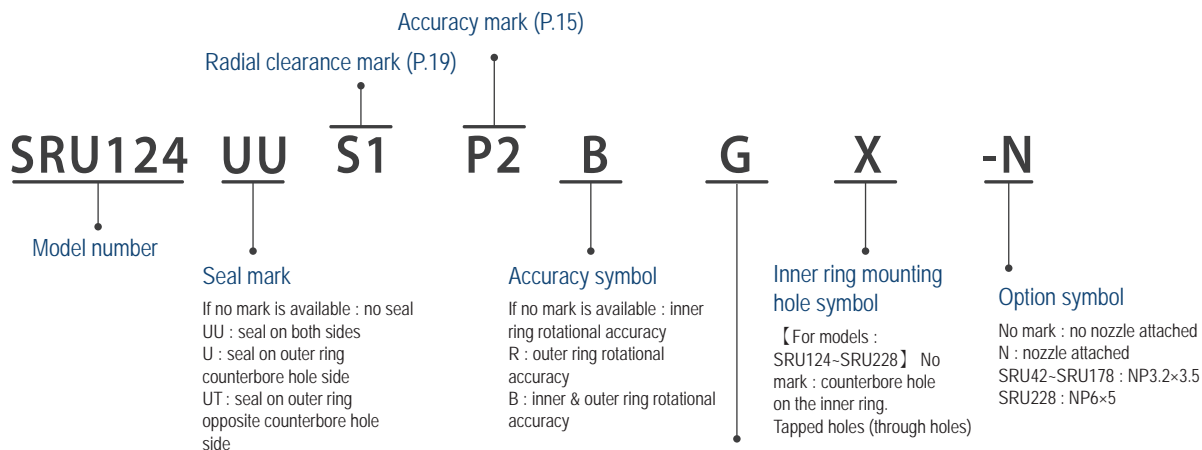

Mounting hole orientation

【 For models : SRU124~SRU228 (except X models) 】
No mark : the counterbore holes on inner and outer rings are in the same direction
G : The counterbore holes on inner and outer rings are in reverse direction

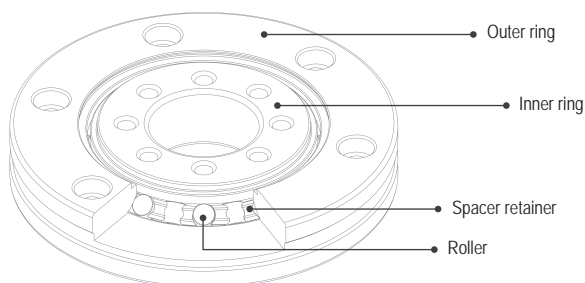

Unit : mm

Shaft Diameter	Model Number	Main Dimensions					Shoulder Height		Basic Load Rating <small>(Radial)</small>		Mass
		Inner Diameter d	Outer Diameter D	Width T	Greasing Hole d1	Chamfer r_{min}	da	Dh	C kN	C₀ kN	kg
20	SRU42	20	70	12	3	0.5	36	46	7.3	8.33	0.28
35	SRU66	35	95	15	3	0.5	58	75	17.53	22.31	0.6
55	SRU85	55	120	15	3	0.5	78	94	20.31	29.55	1.1
80	SRU124(G) SRU124X	80	165	22	3	1	115	133	33	50.85	2.61
90	SRU148(G) SRU148X	90	210	25	3	1.5	134	161	49	76.83	4.95
115	SRU178(G) SRU178X	115	240	28	3	1.5	162	194	80.32	134.9	6.78
160	SRU228(G) SRU228X	160	295	35	6.1	2	207	247	103.5	172.8	10.5

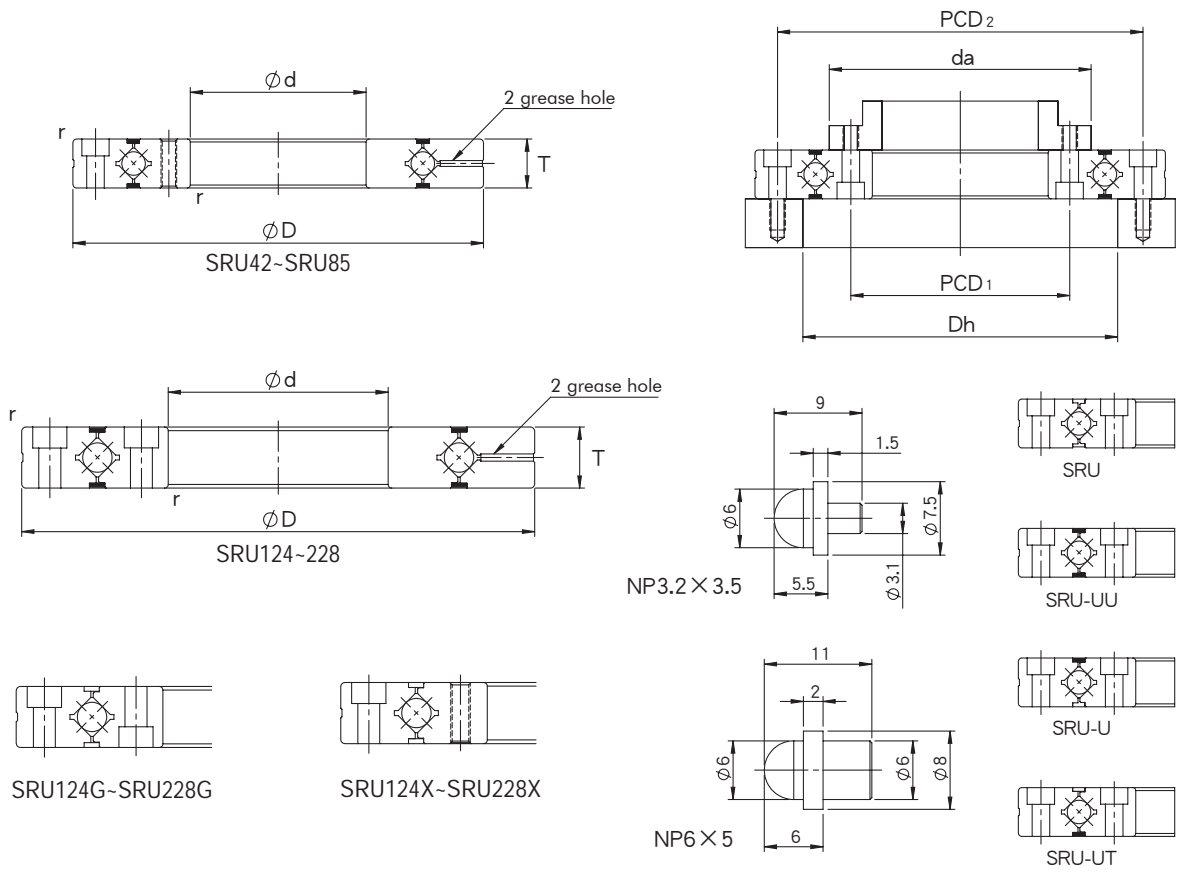

Mounting Hole Specification			
Inner Ring		Outer Ring	
PCD1	Mounting Hole	PCD2	Mounting Hole
28	6-M3 Through	57	6-Ø3.5 Through , Ø6.5 hole depth 3.5
45	8-M4 Through	83	8-Ø4.5 Through , Ø8 hole depth 4.5
65	8-M5 Through	105	8-Ø5.5 Through , Ø10 hole depth 5.5
97	10-Ø5.5 Through , Ø10 hole depth 5.5 10-M5 Through	148	10-Ø5.5 Through , Ø10 hole depth 5.5
112	12-Ø9.0 Through , Ø14 hole depth 8.5 12-M8 Through	187	12-Ø9.0 Through , Ø14 hole depth 8.5
139	12-Ø9.0 Through , Ø14 hole depth 8.5 12-M8 Through	217	12-Ø9.0 Through , Ø14 hole depth 8.5
184	12-Ø11 Through , Ø18 hole depth 10.8 12-M10 Through	270	12-Ø11 Through , Ø18 hole depth 10.8

SRB Model (Split Outer Ring model for inner ring rotation)

SRB20030

Model number

UU

Seal mark

If no mark is available: no seal
 UU : seal on both sides
 U : seal on either side

S1

Radial clearance mark (P.19)

S1 : Preloaded (negative clearance)
 C1 : No preload (positive clearance)

P2

Accuracy mark (P.15)

if no mark is available: ordinary grade (0 grade)
 P5 : rotating accuracy grade 5
 PS5 : rotating accuracy grade 5+size accuracy grade 5
 P4 : rotating accuracy grade 4
 PS4 : rotating accuracy grade 4 +size accuracy grade 4
 P2 : rotating accuracy grade 2
 PS2 : rotating accuracy grade 2 + size accuracy grad 2

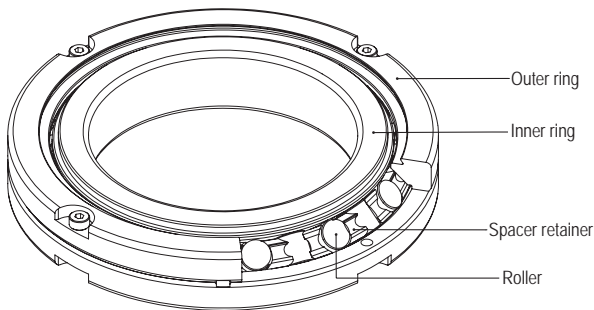

Unit : mm

Shaft Diameter	Model Number	Main Dimensions						Shoulder Height		Basic Load Rating ^(Radial)		Mass
		Inner Diameter d	Outer Diameter D	Width T, T₁	Greasing Hole		Chamfer r_{min}	d_a	D_h	C kN	C₀ kN	kg
					w	h						
20	SRB2008	20	36	8	2.1	0.7	0.5	24	30	3.2	3.1	0.06
25	SRB2508	25	41	8	2.1	0.7	0.5	29	35	3.6	3.8	0.07
30	SRB3010	30	55	10	2.6	0.8	0.6	37.5	46.5	7.4	8.4	0.14
35	SRB3510	35	60	10	2.6	0.8	0.6	41.5	51	7.6	9.1	0.12
40	SRB4010	40	65	10	2.6	0.8	0.6	47	58	8.3	10.8	0.18
45	SRB4510	45	70	10	2.6	0.8	0.6	51.5	61	8.6	11.1	0.15
50	SRB5013	50	80	13	2.6	1.5	0.6	57	72.5	16.6	20.7	0.28
60	SRB6013	60	90	13	2.6	1.5	0.6	67.5	82.5	18	24.1	0.32
70	SRB7013	70	100	13	2.6	1.5	0.6	78.5	91.5	19.5	27.9	0.37
80	SRB8016	80	120	16	3.1	1.5	0.8	91.5	110	30	42	0.72
90	SRB9016	90	130	16	3.1	1.5	1.0	98.8	117	31.3	45.1	0.77
100	SRB10016	100	140	16	3.6	1.5	1.0	110	128	31.8	48.8	0.82
100	SRB10020	100	150	20	3.6	1.5	1.0	117	132	33	51	1.47
110	SRB11012	110	135	12	2.6	0.8	0.6	118	126	12.6	24	0.42
110	SRB11015	110	145	15	3.6	1.5	0.6	123	135	23.8	41.8	0.76
110	SRB11020	110	160	20	3.6	1.5	1.0	121	139	34	54	1.58
120	SRB12016	120	150	16	3.6	1.5	0.8	128	140	24.3	43.4	0.74
120	SRB12025	120	180	25	3.6	2.1	1.5	134	163	66.8	100.2	2.62

Note) (w) and (h) greasing hole dimensions in the detailed view are reference values.

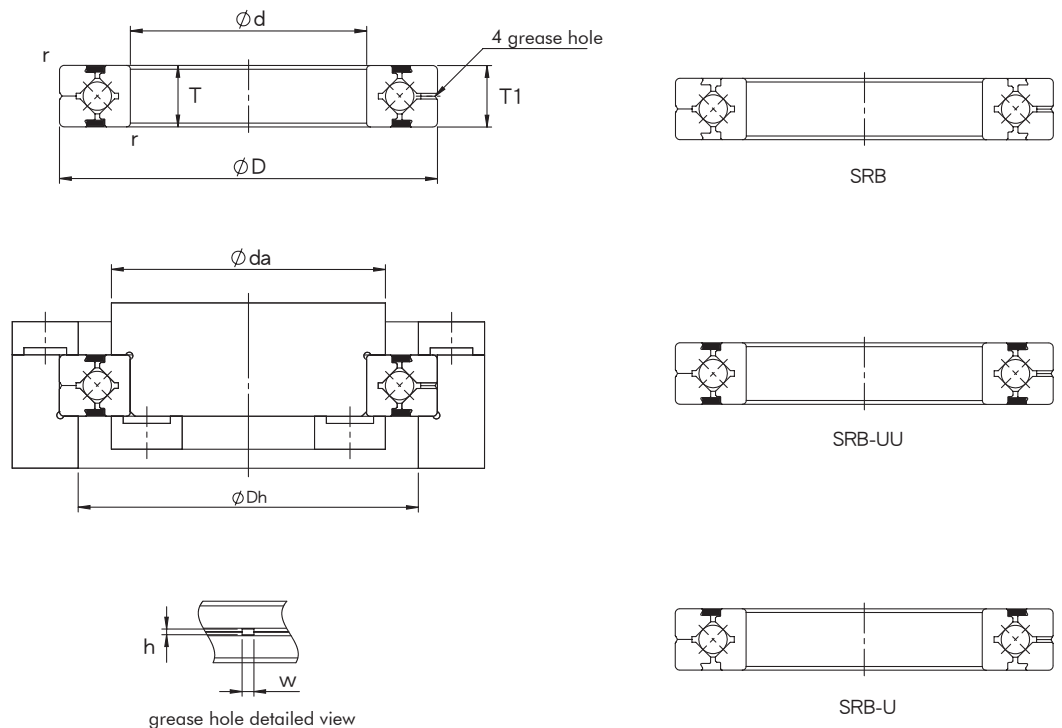

Unit : mm

Shaft Diameter	Model Number	Main Dimensions						Shoulder Height		Basic Load Rating (Radial)		Mass
		Inner Diameter d	Outer Diameter D	Width T, T_1	Greasing Hole		Chamfer r_{min}	da	Dh	C kN	C_0 kN	kg
					w	h						
130	SRB13015	130	160	15	3.6	1.5	0.8	136	151	25	46.9	0.74
130	SRB13025	130	190	25	3.6	2.1	1.2	144	173	69.7	107.3	2.8
140	SRB14016	140	175	16	2.6	1.5	0.8	148	163	26	50.3	1.1
140	SRB14025	140	200	25	3.6	2.1	1.2	155	184	74.7	121	2.98
150	SRB15013	150	180	13	2.6	1.5	0.5	158	171	27.1	53.7	0.66
150	SRB15025	150	210	25	3.6	2.1	1.2	165	193	76.5	128	3.18
150	SRB15030	150	230	30	4.6	3.1	1.5	174	210	100	156	5.2
160	SRB16025	160	220	25	3.6	2.1	1.2	172	205	81.6	135	3.12
170	SRB17020	170	220	20	3.6	1.5	1.2	185	197	29.2	62	2.2
180	SRB18025	180	240	25	3.6	1.8	1.2	196	224	84.3	143	3.41
190	SRB19025	190	240	25	3.6	1.5	0.8	203	221	41.8	82.7	2.97
200	SRB20025	200	260	25	3.6	1.8	1.8	214	246	84.1	157	4.2
200	SRB20030	200	280	30	4.6	2.8	1.8	222	257	113	202	6.8
200	SRB20035	200	295	35	5.1	2.8	1.8	224	271	151	251	9.8
220	SRB22025	220	280	25	3.6	1.8	1.8	236	264	92.1	173	4
240	SRB24025	240	300	25	3.6	1.8	2.2	255	282	68.4	146	4.7
250	SRB25025	250	310	25	3.6	1.8	2.2	264	291	69.2	152	5.2

Note) (w) and (h) greasing hole dimensions in the detailed view are reference values.

SRBE Model (One piece inner & outer ring)

SRBE20030

Model number

UU

Seal mark

If no mark is available : no seal
 UU : seal on both sides
 U : seal on either side

S1

Radial clearance mark (P.19)

S1 : Preloaded (negative clearance)
 C1 : No preload (positive clearance)

P2

Accuracy mark (P.15)

if no mark is available : ordinary grade (0 grade)
 P5 : rotating accuracy grade 5
 PS5 : rotating accuracy grade 5+size accuracy grade 5
 P4 : rotating accuracy grade 4
 PS4 : rotating accuracy grade 4 +size accuracy grade 4
 P2 : rotating accuracy grade 2
 PS2 : rotating accuracy grade 2 + size accuracy grad 2

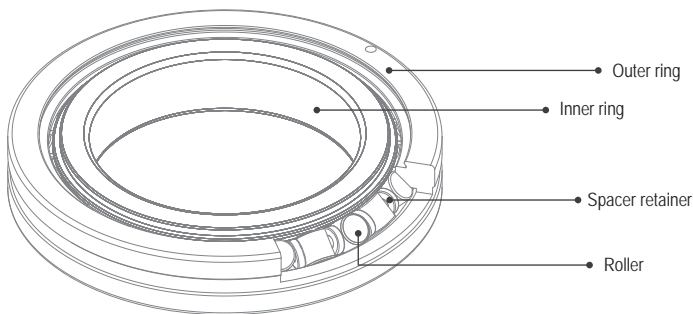

Unit : mm

Shaft Diameter	Model Number	Main Dimensions					Shoulder Height		Basic Load Rating ^(Radial)		Mass
		Inner Diameter d	Outer Diameter D	Width T, T ₁	Greasing Hole	Chamfer r _{min}	da	Dh	C kN	C ₀ kN	kg
20	SRBE2008	20	36	8	2-Φ2	0.5	24	30	3.2	3.1	0.06
25	SRBE2508	25	41	8	2-Φ2	0.5	29	35	3.6	3.8	0.07
30	SRBE3010	30	55	10	2-Φ2	0.6	37.5	46.5	7.4	8.4	0.14
35	SRBE3510	35	60	10	2-Φ2	0.6	41.5	51	7.6	9.1	0.12
40	SRBE4010	40	65	10	2-Φ2	0.6	47	58	8.3	10.8	0.18
45	SRBE4510	45	70	10	2-Φ2	0.6	51.5	61	8.6	11.1	0.15
50	SRBE5013	50	80	13	2-Φ3	0.6	57	72.5	16.6	20.7	0.28
60	SRBE6013	60	90	13	2-Φ3	0.6	67.5	82.5	18	24.1	0.32
70	SRBE7013	70	100	13	2-Φ3	0.6	78.5	91.5	19.5	27.9	0.37
80	SRBE8016	80	120	16	2-Φ3	0.8	91.5	110	30	42	0.72
90	SRBE9016	90	130	16	2-Φ3	1.0	98.8	117	31.3	45.1	0.77
100	SRBE10016	100	140	16	2-Φ3	1.0	110	128	31.8	48.8	0.82
100	SRBE10020	100	150	20	2-Φ3	1.0	117	132	33	51	1.47
110	SRBE11012	110	135	12	2-Φ3	0.6	118	126	12.6	24	0.42
110	SRBE11015	110	145	15	2-Φ3	0.6	123	135	23.8	41.8	0.76
110	SRBE11020	110	160	20	2-Φ3	1.0	121	139	34	54	1.58
120	SRBE12016	120	150	16	2-Φ3	0.8	128	140	24.3	43.4	0.74
120	SRBE12025	120	180	25	2-Φ3	1.5	134	163	66.8	100.2	2.62

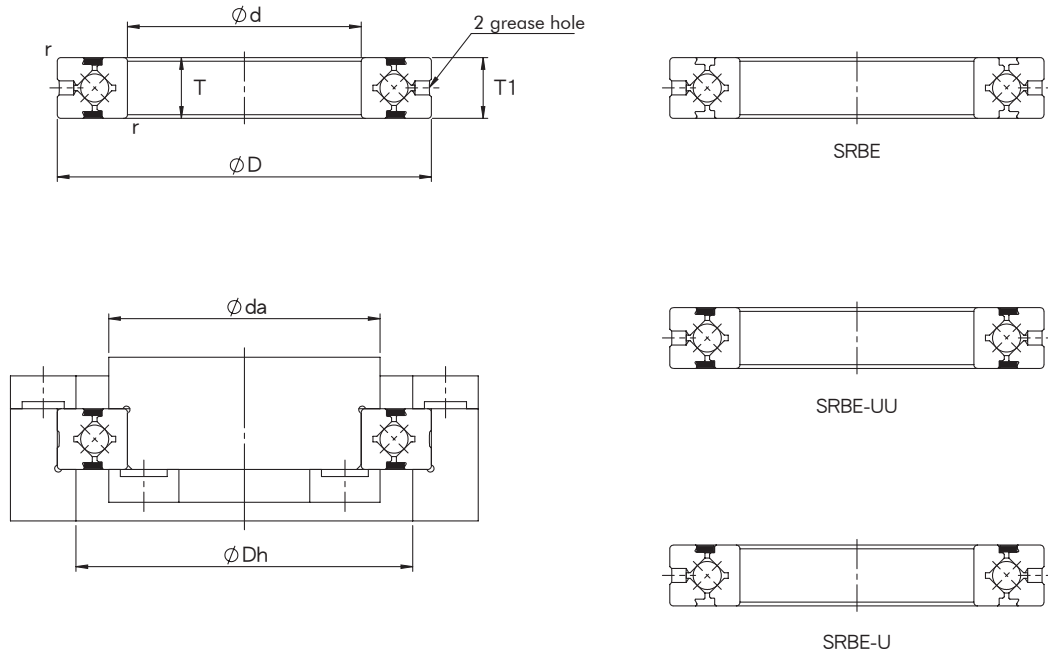

Unit : mm

Shaft Diameter	Model Number	Main Dimensions					Shoulder Height		Basic Load Rating <small>(Radial)</small>		Mass
		Inner Diameter d	Outer Diameter D	Width T, T_1	Greasing Hole	Chamfer r_{min}	da	Dh	C kN	C_0 kN	kg
130	SRBE13015	130	160	15	2- $\phi 3$	0.8	136	151	25	46.9	0.74
130	SRBE13025	130	190	25	2- $\phi 3$	1.2	144	173	69.7	107.3	2.8
140	SRBE14016	140	175	16	2- $\phi 3$	0.8	148	163	26	50.3	1.1
140	SRBE14025	140	200	25	2- $\phi 3$	1.2	155	184	74.7	121	2.98
150	SRBE15013	150	180	13	2- $\phi 3$	0.5	158	171	27.1	53.7	0.66
150	SRBE15025	150	210	25	2- $\phi 3$	1.2	165	193	76.5	128	3.18
150	SRBE15030	150	230	30	2- $\phi 3$	1.5	174	210	100	156	5.2
160	SRBE16025	160	220	25	2- $\phi 3$	1.2	172	205	81.6	135	3.12
170	SRBE17020	170	220	20	2- $\phi 3$	1.2	185	197	29.2	62	2.2
180	SRBE18025	180	240	25	2- $\phi 3$	1.2	196	224	84.3	143	3.41
190	SRBE19025	190	240	25	2- $\phi 3$	0.8	203	221	41.8	82.7	2.97
200	SRBE20025	200	260	25	2- $\phi 3$	1.8	214	246	84.1	157	4.2
200	SRBE20030	200	280	30	2- $\phi 3$	1.8	222	257	113	202	6.8
200	SRBE20035	200	295	35	2- $\phi 3$	1.8	224	271	151	251	9.8
220	SRBE22025	220	280	25	2- $\phi 3$	1.8	236	264	92.1	173	4
240	SRBE24025	240	300	25	2- $\phi 3$	2.2	255	282	68.4	146	4.7
250	SRBE25025	250	310	25	2- $\phi 3$	2.2	264	291	69.2	152	5.2

SRAU Model (One piece inner & outer ring)

SRAU8008

UU

S1

P5

B

Model number

Seal mark

If no mark is available: no seal
 UU : seal on both sides
 U : seal on either side

Radial clearance mark (P.19)

S1 : Preloaded (negative clearance)
 C1 : No preload (positive clearance)

Accuracy mark (P.16)

if no mark is available: ordinary grade (0 grade)
 P6 : rotating accuracy grade 6
 P5 : rotating accuracy grade 5
 P4 : rotating accuracy grade 4

Accuracy symbol

If no mark is available: inner ring rotational accuracy
 R : outer ring rotational accuracy
 B : inner & outer ring rotational accuracy

Width:5mm

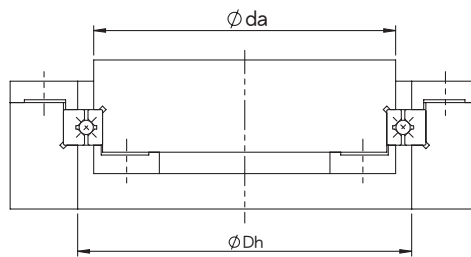
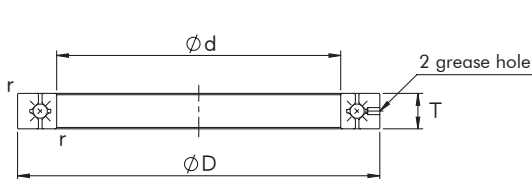

Unit : mm

Shaft Diameter	Model Number	Main Dimensions						Shoulder Height		Basic Load Rating (Radial)		Mass
		ID d	OD D	Pitch Circle Diameter dw	Width T	Greasing Hole do	Chamfer r _{min}	da	Dh	C kN	C ₀ kN	kg
10	SRAU1005	10	21	14.7	5	1	0.15	12.5	17	1.12	0.809	0.009
15	SRAU1505	15	26	19.7	5	1	0.15	17.5	22	1.32	1.1	0.012
20	SRAU2005	20	31	24.7	5	1	0.15	22.5	27	1.49	1.4	0.015
30	SRAU3005	30	41	34.7	5	1	0.15	32.5	37	1.89	2.14	0.021
40	SRAU4005	40	51	44.7	5	1	0.15	42.5	47	2.14	2.74	0.027
50	SRAU5005	50	61	54.7	5	1	0.15	52.5	57	2.43	3.49	0.032
60	SRAU6005	60	71	64.7	5	1	0.15	62.5	67	2.63	4.09	0.038
70	SRAU7005	70	81	74.7	5	1	0.15	72.5	77	2.81	4.68	0.044
80	SRAU8005	80	91	84.7	5	1	0.15	82.5	87	3.05	5.43	0.5
90	SRAU9005	90	101	94.7	5	1	0.15	92.5	97	3.19	6.03	0.056
100	SRAU10005	100	111	104.7	5	1	0.15	102.5	107	3.37	6.63	0.061

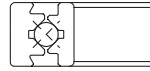

SRAU

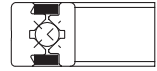

SRAU-UU

Width:8mm.13mm

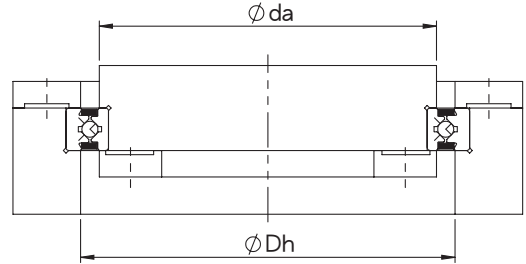
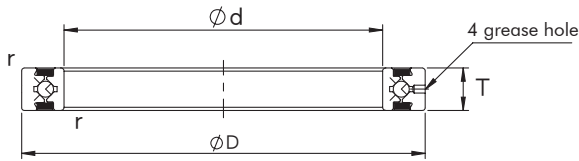

Unit : mm

Shaft Diameter	Model Number	Main Dimensions						Shoulder Height		Basic Load Rating ^(Radial)		Mass
		ID d	OD D	Pitch Circle Diameter dw	Width T	Greasing Hole do	Chamfer r _{min}	da	Dh	C kN	C ₀ kN	kg
50	SRAU5008	50	66	57	8	1.5	0.5	53.5	60.5	5.1	7.19	0.08
60	SRAU6008	60	76	67	8	1.5	0.5	63.5	70.5	5.68	8.68	0.09
70	SRAU7008	70	86	77	8	1.5	0.5	73.5	80.5	5.98	9.8	0.1
80	SRAU8008	80	96	87	8	1.5	0.5	83.5	90.5	6.37	11.3	0.11
90	SRAU9008	90	106	97	8	1.5	0.5	93.5	100.5	6.76	12.4	0.12
100	SRAU10008	100	116	107	8	1.5	0.5	103.5	110.5	7.15	13.9	0.14
110	SRAU11008	110	126	117	8	1.5	0.5	113.5	120.5	7.45	15	0.15
120	SRAU12008	120	136	127	8	1.5	0.5	123.5	130.5	7.84	16.5	0.17
130	SRAU13008	130	146	137	8	1.5	0.5	133.5	140.5	7.94	17.6	0.18
140	SRAU14008	140	156	147	8	1.5	0.5	143.5	150.5	8.33	19.1	0.19
150	SRAU15008	150	166	157	8	1.5	0.5	153.5	160.5	8.82	20.6	0.2
160	SRAU16013	160	186	172	13	2	0.8	165	179	23.3	44.9	0.59
170	SRAU17013	170	196	182	13	2	0.8	175	189	23.5	46.5	0.64
180	SRAU18013	180	206	192	13	2	0.8	185	199	24.5	49.8	0.68
190	SRAU19013	190	216	202	13	2	0.8	195	209	24.9	51.5	0.69
200	SRAU20013	200	226	212	13	2	0.8	205	219	25.8	54.5	0.71

SRAUF Model(One piece inner & outer ring)

SRAUF2005

S1

P5

Model number

Radial clearance mark (P.18)

Accuracy mark (P.18)

S1 : Preloaded (negative clearance)
C1 : No preload (positive clearance)

if no mark is available: ordinary grade (0 grade)
P6 : rotating accuracy grade 6
P5 : rotating accuracy grade 5
P4 : rotating accuracy grade 4

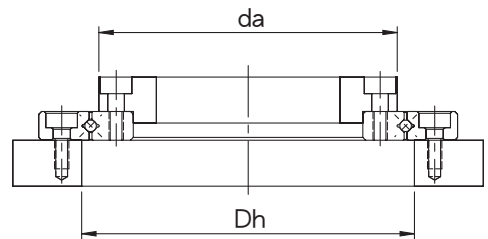
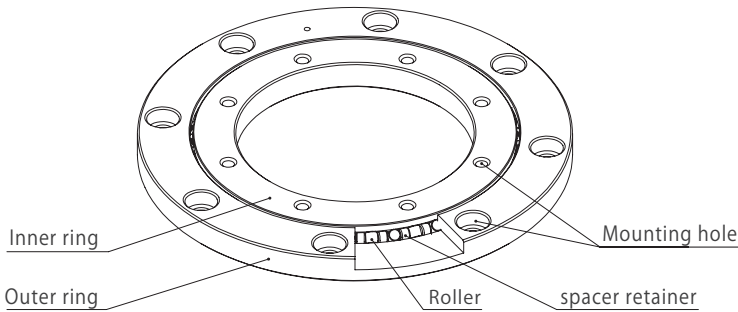
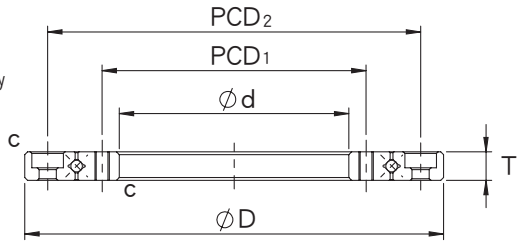

Unit : mm

Shaft Diameter	Model Number	Main Dimensions				Shoulder Height		Basic Load Rating ^(Radial)		Mass
		Inner Diameter d	Outer Diameter D	Width T	Chamfer C _{min}	da	Dh	C kN	C ₀ kN	kg
10	SRAUF1005	10	43	5	0.15	21.5	28	1.50	1.41	0.046
20	SRAUF2005	20	53	5	0.15	31.5	38	1.89	2.15	0.066
30	SRAUF3005	30	63	5	0.15	41.5	47.5	2.14	2.75	0.083
40	SRAUF4005	40	73	5	0.15	51.5	58	2.44	3.49	0.103

Mounting Hole Specification

Inner Ring			Outer Ring	
PCD1	Mounting Hole	PCD2	Mounting Hole	
10	6-M2.5 Through	35	6- ϕ 2.9 through , ϕ 5.5 Counterbore depth 2.8	
20	6-M2.5 Through	45	6- ϕ 2.9 through , ϕ 5.5 Counterbore depth 2.8	
30	8-M2.5 Through	55	8- ϕ 2.9 through , ϕ 5.5 Counterbore depth 2.8	
40	8-M2.5 Through	65	8- ϕ 2.9 through , ϕ 5.5 Counterbore depth 2.8	

SSHF Model (One piece inner & outer ring)

SSHF14

Model number

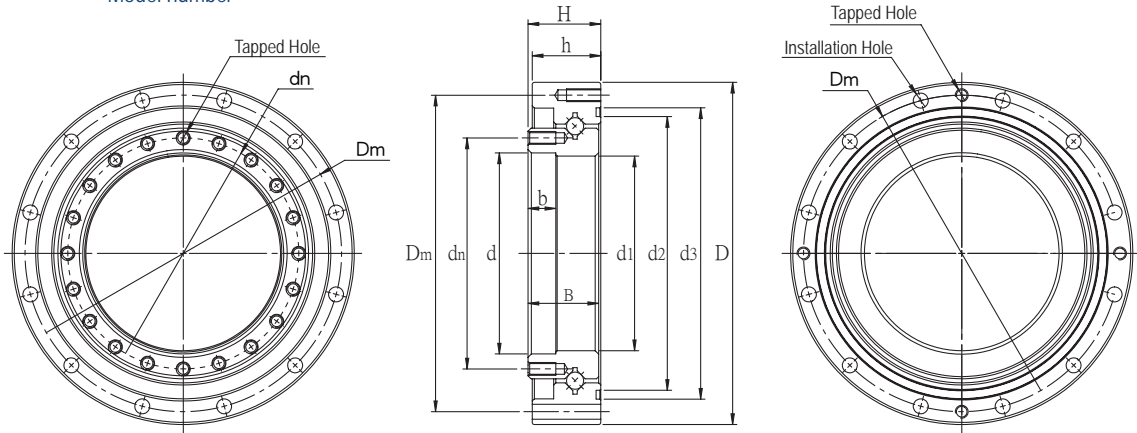

Unit : mm

Model Number	Main Dimensions								
	D	d	d1	d2	d3	H	h	B	b
SSHF14	70	38	36	53	57	15.1	14.1	14.7	5
SSHF17	80	47	45.5	64	68.1	17	16	16.5	6.5
SSHF20	90	54	51.3	72.6	78	18.5	17.5	17.5	7
SSHF25	110	67	64.2	90	94.8	20.7	19.7	19.7	7.5
SSHF32	142	88	84	117.5	123	24.4	23.4	22.9	8

Unit : mm

Model Number	Installation Hole Dimension (PCD&PEC)					Basic Load Rating (R_{Radial})		Mass
	Outer Ring			Inner Ring		C kN	C ₀ kN	kg
	D_m	Installation Hole	Tapped Hole	d_n	Tapped Hole			
SSHF14	64	8- Φ 3.5	2-M3	44	12-M3	10.34	13.82	0.1
SSHF17	74	12- Φ 3.5	4-M3	54	20-M3	10.07	14.12	0.34
SSHF20	84	12- Φ 3.5	4-M3	62	4-M3 16-M3	20.73	28.01	0.45
SSHF25	102	12- Φ 4.5	4-M3	77	4-M3 16-M4	23.22	34.64	0.7
SSHF32	132	12- Φ 5.5	4-M4	100	8-M4 16-M5	40.81	64.07	1.55

SCSG Model (Split outer ring)

SCSG14

Model number

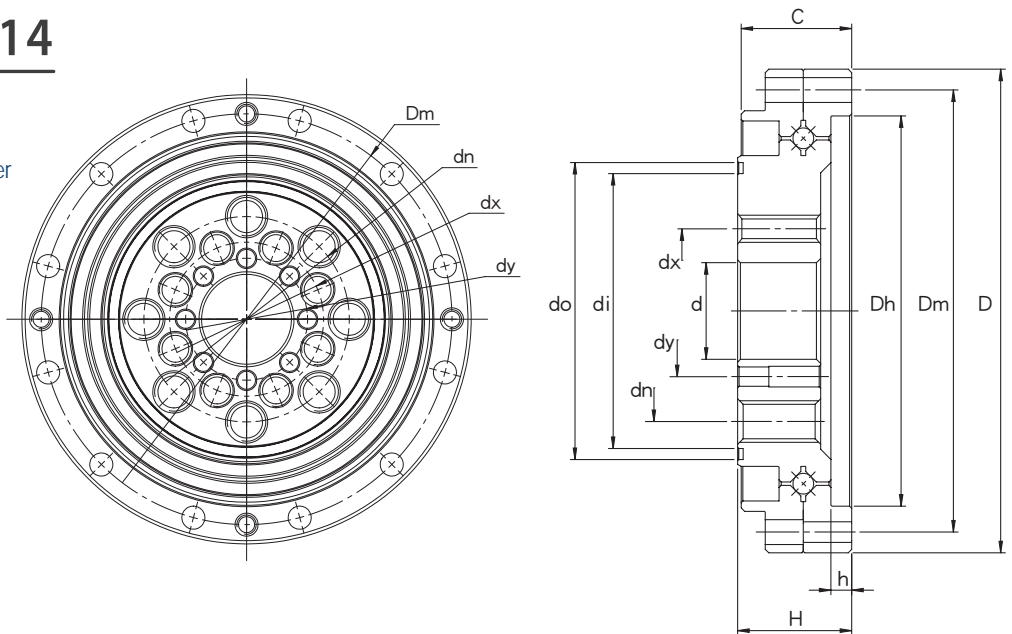

Unit : mm

Model Number	Main Dimensions								Basic Load Rating (Radial)		Mass
	D	Dh	d	do	di	H	h	C	C kN	Co kN	kg
SCSG14	55	41.8	11	29.7	28.3	16.5	2.5	16	4.88	5.68	0.13
SCSG17	62	49	10	36	33.8	16.5	2.7	16	5.46	7.02	0.22
SCSG20	70	56.5	14	43	39.8	16.5	3	16	6.67	9.66	0.2
SCSG25	85	68	20	55.4	52.5	18.5	2	18	10.3	14.76	0.45
SCSG32	112	90	26	74.1	68.4	22.5	3	21.5	22.6	32.97	0.88

Unit : mm

Model Number	Installation Hole Size (PCD&PEC)							
	Outer Ring		Inner Ring					
	Dm	Installation Hole	dn	Tapped Hole	dx	Tapped Hole	dy	Hole Size
SCSG14	49	8-Φ3.5	23	6-M4	17	6-M4	15	6-Φ2.5
SCSG17	56	10-Φ3.5	27	6-M5	19	6-M5	15	6-Φ3
SCSG20	64	12-Φ3.5	32	8-M6	24	8-M5	19	8-Φ3
SCSG25	79	16-Φ3.5	42	8-M8	30	8-M6	26	8-Φ3
SCSG32	104	16-Φ4.5	55	8-M10	40	8-M8	34	4-Φ5